

Landfill Gas Filtration



Absolute Quality is our Goal... Genuine Service is our Habit!

As waste decomposes in a landfill, gas is produced composed mainly of methane and carbon dioxide. Landfill gas can be a reliable energy source for both industrial and residential use, and its conversion reduces greenhouse gas emissions, pollution and energy costs. However, landfills are naturally dirty and retain particulate and moisture. Inadequate filtration of produced gas will lead to extraction system damage, heat exchanger fouling, and can lead to safety hazards at energy usage sites.

Absolute Quality:

PRM manufactures Landfill Gas Filtration Packages for your system to eliminate particles and moisture that could otherwise damage downstream equipment. This filtration is a pre-treatment for gas going into siloxane filters, blower stations or with gas utilization systems.

Standard Features:

- 304 SS Housings and Piping
- Buna-N Seals
- Low Pressure Drop
- Skid Mounted
- Teflon® Filters
- High Performance SS Butterfly Valves
- Easy Maintenance/ Filter Access

Flow Rates from 500 - 10,000 CFM



****Options and Services****

- Upgrade to 316 SS Construction and Viton® Seals for Extreme Conditions
- Integration into New or Existing Systems
- Installation, Operations and Maintenance Services
- Customized Systems for On-Site Requirements

Contact sales@prm-net.com for information on PRM Landfill Products and Landfill Gas Systems

(888) TREAT-IT

www.prm-net.com

Product Recovery Management, Incorporated

(888) TREAT-IT

888-873-2848 • 919-957-8890 • www.prm-net.com • sales@prm-net.com

Butner, NC • Atlanta, GA • Webster, NY • Raymond, NH • Lakeland, FL

Landfill Gas Filtration



Absolute Quality is our Goal... Genuine Service is our Habit!

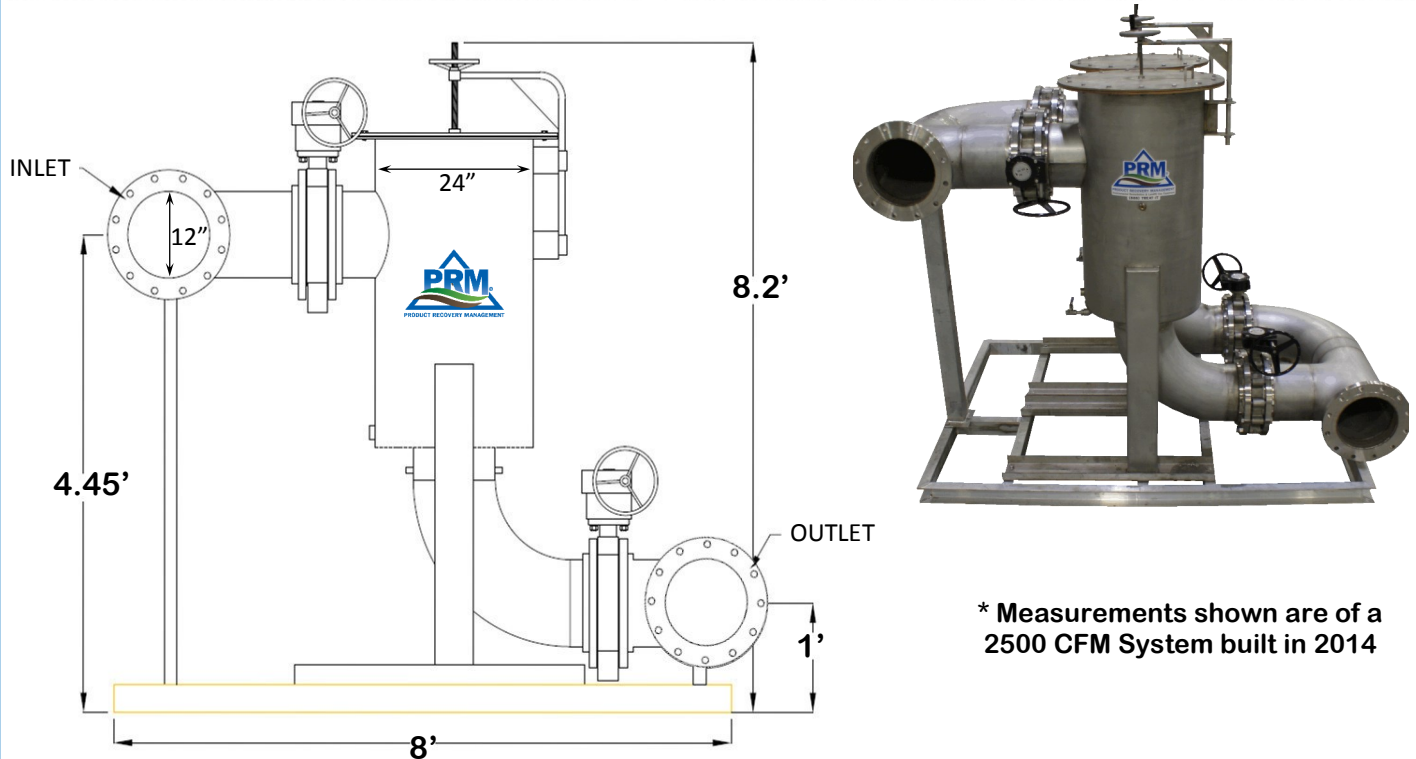

* Measurements shown are of a 2500 CFM System built in 2014



Filter Element inside of Housing with Cover



Filter Element inside of Housing without Cover

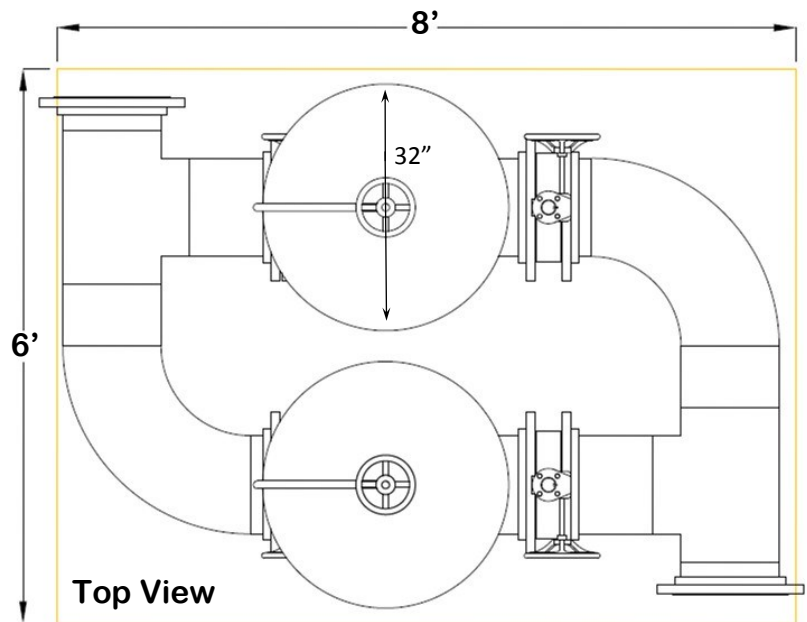

Product Recovery Management, Incorporated

(888) TREAT-IT

888-873-2848 • 919-957-8890 • www.prm-net.com • sales@prm-net.com

Butner, NC • Atlanta, GA • Webster, NY • Raymond, NH • Lakeland, FL